



TECHNICAL DATA

GENERAL	DR602AHG
Unloading system	Rotating
Load capacity	6000
Chassis	Articulated
Water hopper capacity	1665
Level hopper capacity	2455
Heaped hopper capacity	3154
Empty weight	4210 (4480*)
Transmission	Hydrostatic
ENGINE	
Brand	DEUTZ
Model	TD2.9 L4
Power	55,4
Operating speed	2200
Torque	320@1600
No. of cylinders	4
Emissions	Stage V
Injection	Common Rail and electronic management
Exhaust aftertreatment	DPF (Diesel particulate filter)
Noise	101
DRIVING	
Max. speed	25
Maximum gradient	49
External turning radius	5900
Traction	4x4
Tyres	405/70-20
HYDRAULIC SYSTEM	
Hydraulic circuit	Gear pump
Flow rate	50
Working pressure	180
TANK CAPACITY	
Fuel	60
Hydraulic system	56
BRAKES	
Service	Sealed brakes. Hydraulic drive
Parking	Negative brake and electro-hydraulic release

* With closed cab.

DIMENSIONS

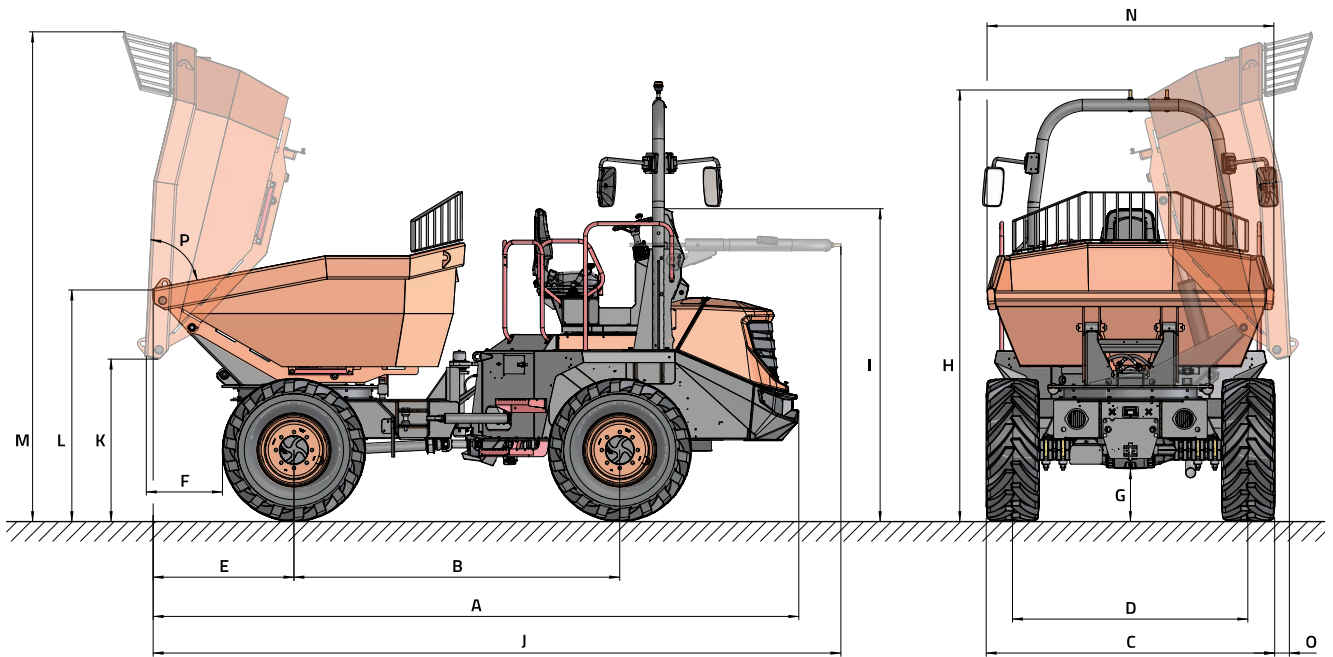

DIMENSIONS (mm)	DR602AHG
A	4940
B	2490
C	2210
D	1800
E	1080
F	580
G	400
H	3300 (2980*)
I	2530
J	5260
K	1210
L	1740
M	3750
N	2200
O	110
DIMENSIONS (°)	
P	75

* With closed cab

AUSA

www.ausa.com

Products are subject to modifications without prior notice. Images throughout the spec sheet may refer to non-standard machines or non-available configurations depending on models.

AUSA's logo and corporate identity are property of the Company, they cannot be used without authorization.